

Clutch System

GENERAL

SPECIFICATIONS.....	CH-2
LUBRICANTS.....	CH-3
SPECIAL TOOLS.....	CH-3
TROUBLESHOOTING.....	CH-4

CLUTCH SYSTEM

CLUTCH CONTROL

SERVICE ADJUSTMENT PROCEDURE	CH-6
------------------------------------	------

CLUTCH COVER AND DISC

COMPONENTS.....	CH-8
REMOVAL.....	CH-9
INSPECTION	CH-9
INSTALLATION.....	CH-10

CLUTCH MASTER CYLINDER

COMPONENTS.....	CH-12
DISASSEMBLY	CH-13
INSPECTION	CH-13
REASSEMBLY	CH-13

CLUTCH PEDAL

COMPONENTS.....	CH-14
REMOVAL.....	CH-15
INSPECTION	CH-15
INSTALLATION.....	CH-15

CLUTCH RELEASE CYLINDER

COMPONENTS.....	CH-16
REMOVAL.....	CH-17
INSTALLATION.....	CH-17
DISASSEMBLY	CH-17
INSPECTION	CH-18
REASSEMBLY	CH-18

GENERAL

SPECIFICATIONS E374E2C2

Clutch operating method	Hydraulic type
Clutch disc - Type - Facing diameter (Outside x Inside) mm (in.)	Single dry with diaphragm. 215 x 145 (8.5 x 5.7)
Clutch cover assembly - Type	Diaphragm spring strap
Clutch release cylinder * I.D. mm (in.)	2.0L : 19.05 (0.76) 2.7L : 20.64 (0.82)
Clutch master cylinder * I.D. mm (in.)	15.87(0.62)

* I.D. : Inside Diameter

SERVICE STANDARD

Clutch pedal free play	6~13 mm (0.24~0.52 in.)
Clutch pedal height	166.9 mm (6.676 in.)
Clutch pedal stroke	2.0L : 145 mm (5.7 in.) 2.7L : 152 mm (6.1 in.)
Limit Clutch disc rivet sink Diaphragm spring end height difference Clutch release cylinder clearance to piston Clutch master cylinder clearance to piston	1.1 mm (0.044 in.) 0.5 mm (0.02 in.) 0.15 mm (0.006 in.) 0.15 mm (0.006 in.)

unit of measure : mm (inch)

TIGHTENING TORQUE

Item	Nm	kgf.cm	lbf.ft
Clutch pedal to pedal support member (Clutch pedal bracket)	19~28	190~280	14~20
Clutch pedal support member to master cylinder	8~10	80~100	6~7
Clutch tube flare nut	13~17	130~170	9~13
Clutch tube bracket	4~6	40~60	3~4
Reservoir band	13~17	130~170	9~13
Clutch release cylinder	15~22	150~220	11~16
Clutch release cylinder union bolt	20~25	200~250	15~18
Clutch cover assembly			
Single mass flywheel	15~22	150~220	11~16
Dual mass flywheel	20~27	200~270	14~19

LUBRICANTS EADFD948

Items	Specified lubricants	Quantity
Contact surface of release bearing and fulcrum of clutch release fork	CASMOLY L 9508	As required
Inner surface of clutch release bearing	CASMOLY L 9508	As required
Inner surface of clutch release cylinder and outer circumference of piston and cup	Brake fluid DOT 3 or DOT 4	As required
Inner surface of clutch disc spline	CASMOLY L 9508	As required
Inner surface of clutch master cylinder and outer circumference of piston assembly	Brake fluid DOT 3 or DOT 4	As required
Clutch master cylinder push rod, clevis pin and washer	Wheel bearing grease SAE J310a, NLGI No.2	As required
Clutch pedal shaft and bushings	SAE J310a, Chassis grease, NLGI-No.1	As required
Contact portion of release fork to release cylinder push rod	CASMOLY L 9508	As required
Input shaft spline	CASMOLY L 9508	As required
Clutch release fork shaft contact portion & bushings	CASMOLY L 9508	About lg.

SPECIAL TOOLS ECEBF57

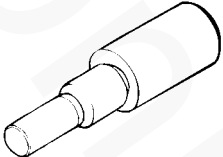
Tool (Number and name)	Illustration	Use
09411-25000 Clutch disc guide	 EODA003A	Installation of the clutch disc

TROUBLESHOOTING EF93CCD2

Symptom		Probable cause	Remedy
Clutch slipping <ul style="list-style-type: none"> • Car will not respond to engine speed during acceleration • Insufficient vehicle speed • Lack of power during uphill driving 		Insufficient clutch pedal free play	Adjust
		Clogged hydraulic system	Correct or replace parts
		Excessive wear of clutch disc facing	Replace
		Hardened clutch disc facing, or oil on surface	Replace
		Damaged pressure plate or flywheel	Replace
		Weak or broken pressure spring	Replace
Difficult gear shifting (gear noise during shifting)		Excessive pedal free play	Adjust
		Hydraulic system fluid leaks, air trapping or clogging	Repair or replace parts
		Unusual wear or corrosion of clutch disc spline	Replace
		Excessive vibration (distortion) of clutch disc	Replace
Clutch noisy	When clutch is not used	Insufficient play of clutch pedal	Adjust
		Excessive wear of clutch disc facing	Replace
	A noise is heard after clutch is disengaged	Unusual wear and/or damage of release bearing	Replace
	A noise is heard when clutch is disengaged	Insufficient grease on the sliding surface of bearing sleeve	Repair
		Improperly installed clutch assembly or bearing	Repair
A noise is heard when car is suddenly rolled with clutch partially engaged	Damaged pilot bushing	Replace	
Difficult to depress clutch pedal		Insufficient lubrication of clutch pedal	Repair
		Insufficient lubrication of the clutch disc spline	Repair
		Insufficient lubrication of the clutch release lever shaft	Repair
		Insufficient lubrication of front bearing retainer	Repair
Difficult to shift gear or cannot shift at all		Excessive clutch pedal free play excessive	Adjust pedal free play
		Clutch release cylinder faulty	Repair release cylinder
		Clutch disc out of true, runout is excessive or lining broken	Inspect clutch disc
		Spline on input shaft or clutch disc dirty or burred	Repair as necessary
		Clutch pressure plate faulty	Replace clutch cover
Clutch slips		Clutch pedal free play insufficient	Adjust pedal free play
		Clogged hydraulic system	Repair or replace parts
		Clutch disc lining oily or worn out	Inspect clutch disc
		Pressure plate faulty	Replace clutch cover
		Release fork binding	Inspect release fork

Symptom	Probable cause	Remedy
Clutch grabs/chatters	Clutch disc lining oily or worn out	Inspect clutch disc
	Pressure plate faulty	Replace clutch cover
	Clutch diaphragm spring bent	Replace clutch cover
	Worn or broken torsion spring	Replace clutch disc
	Engine mounts loose	Repair as necessary
Clutch noisy	Damaged clutch pedal bushing	Replace clutch pedal bushing
	Loose part inside housing	Repair as necessary
	Release bearing worn or dirty	Replace release bearing
	Release fork or linkage sticks	Repair as necessary

CLUTCH SYSTEM

CLUTCH CONTROL

SERVICE ADJUSTMENT

PROCEDURE EDF0A1DB

CLUTCH PEDAL INSPECTION AND ADJUSTMENT

1. Measure the clutch pedal height (from the face of the pedal pad to the floorboard) and the clutch pedal clevis pin play (measured at the face of the pedal pad).

Standard value: (A) 166.9 mm

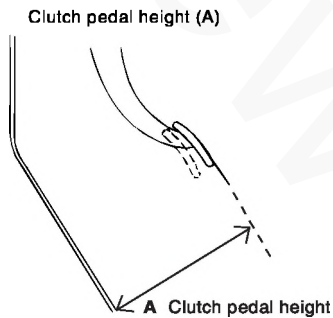

EOOB007A

2. If the clutch pedal clevis pin free-play is not within the standard value range, adjust as follows:
 - Turn and adjust the bolt, then secure by tightening the lock nut.

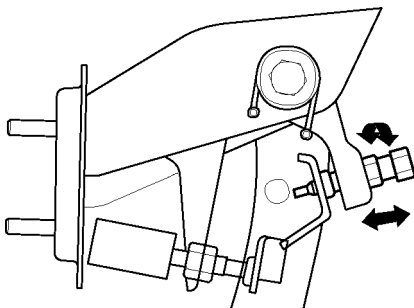

EODA008B

NOTE

After the adjustment, tighten the bolt until it reaches the pedal stopper, and then tighten the lock nut.

- Turn the push rod to agree with the standard value and then secure the push rod with the lock nut.

CAUTION

When adjusting the clutch pedal height or the clutch pedal clevis pin play, be careful not to push the push rod toward the master cylinder.

3. After completing the adjustments, check that the clutch pedal free play (measured at the face of the pedal pad) is within the standard value ranges.

Standard value:

(B) 6~13 mm (0.24~0.52 in.)

(C) 50 mm (1.5 in.)

4. If the clutch pedal free play, and the distance between the clutch pedal and the floor board when the clutch is disengaged, do not meet with the standard values, it may be the result of either air in the hydraulic system or a faulty clutch master cylinder. Bleed the air or disassemble and inspect the master cylinder or clutch.

Clutch pedal free play

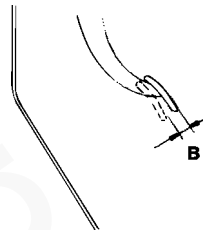

The distance between the clutch pedal and the floor board

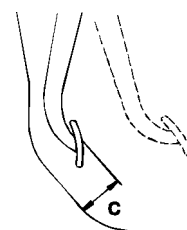

EODA007A

BLEEDING

Whenever the clutch tube, the clutch hose, and/or the clutch master cylinder have been removed, or if the clutch pedal is spongy, bleed the system.

**CAUTION**

Use the specified fluid. Avoid mixing different brands of fluid.

Specified fluid: SAE J1703 (DOT 3 or DOT 4)

1. Loosen the bleeder screw at the clutch release cylinder.
2. Push the clutch pedal down slowly until all is expelled.
3. Hold the clutch pedal down until the bleeder is retightened.
4. Refill the clutch master cylinder with the specified fluid.

**CAUTION**

The rapidly-repeated operation of the clutch pedal in B-C range may cause the release cylinder's position to be forced out from the release cylinder body during air bleeding. Repress the clutch pedal after it returns to the "A" point completely.

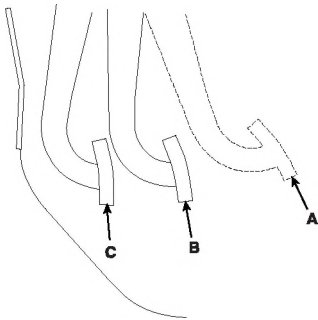

EODA007C

CLUTCH COVER AND DISC

COMPONENTS E837BFE6

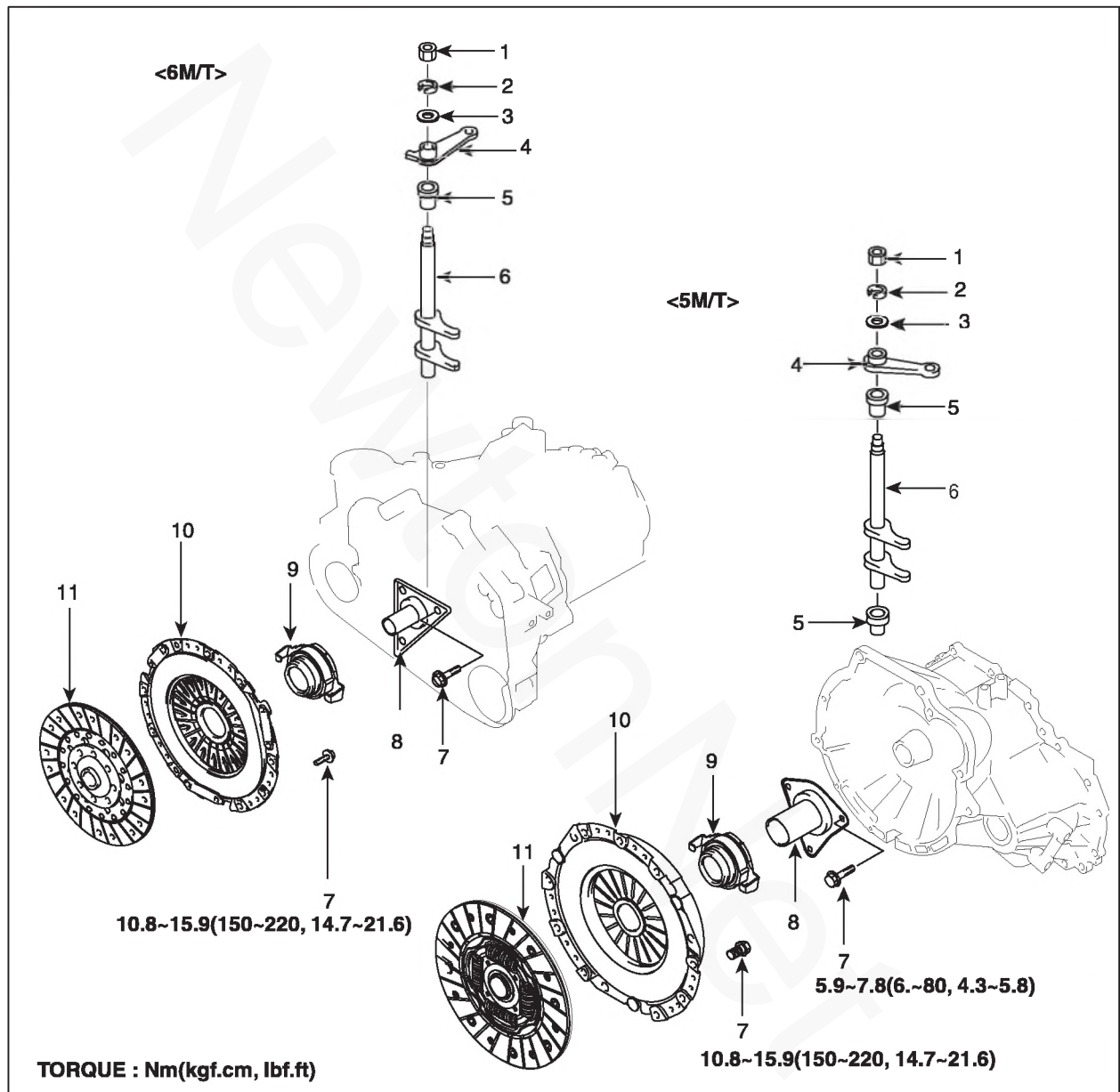

- 1. Nut
- 2. Spring washer
- 3. Plain washer
- 4. Release fork shaft lever
- 5. Bushing
- 6. Clutch release fork shaft

- 7. Bolt
- 8. Release bearing sleeve
- 9. Clutch release bearing
- 10. Clutch cover assembly
- 11. Clutch disc assembly

REMOVAL EB605EE5

1. Drain the clutch fluid and transaxle gear oil.
2. Remove the transaxle assembly.
3. Insert the special tool (09411-25000) in the clutch disc to prevent the disc from falling.
4. Loosen the bolts that attach the clutch cover to the flywheel in a star pattern.
5. Loosen the bolts in succession, one or two turns at a time, to avoid bending the cover flange.

CAUTION

DO NOT clean the clutch disc or release bearing with cleaning solvent.

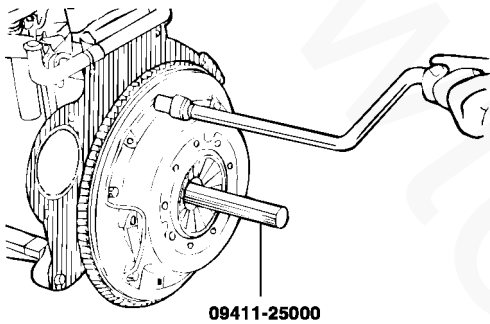

09411-25000

EODA117B

INSPECTION E3EE7280

CLUTCH COVER ASSEMBLY

1. Check the diaphragm spring end for wear and uneven height.
Replace if wear is evident or height difference exceeds the limit.

Limit: 0.3 mm (0.012 in.)

2. Check the pressure plate surface for wear, cracks and color change.
3. Check the rivets for looseness and replace the clutch cover assembly if necessary.

CLUTCH DISC

1. Check the clutch facing for loose rivets, uneven contact, deterioration due to seizure, adhesion of oil, or grease, and replace the clutch disc if defective.
2. Measure the rivet sink and replace the clutch disc if it is out of specification

Limit: 1.1 mm (0.044 in.)

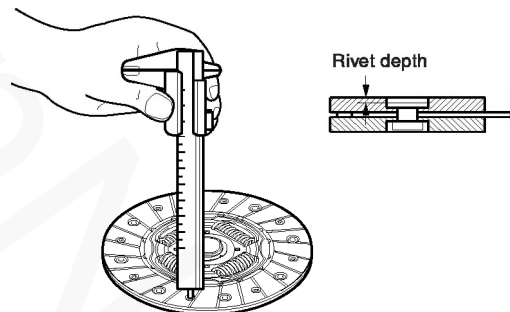

Rivet depth

EODA018A

3. Check for torsion spring play and damage and if defective, replace the clutch disc.
4. Clean the splines on the input shaft and install the clutch disc.
If the disc does not slide smoothly or if play is excessive, replace the clutch disc and/or the input shaft.

CLUTCH RELEASE BEARING

 CAUTION

The release bearing is packed with grease. Do not use cleaning solvent or oil.

1. Check the bearing for seizure, damage or abnormal noise. Also check the diaphragm spring contacting points for wear.
2. Replace the bearing if the release fork contacting points are worn abnormally.

CLUTCH RELEASE FORK

If there is abnormal wear at the point of contact with the bearing, replace the release fork assembly.

INSTALLATION EEEEAC8F

1. Apply multipurpose grease to the release bearing contact surfaces and the release cylinder contact surface of the clutch release fork assembly.

 CAUTION

When installing the clutch, apply grease to each part, but be careful not to apply excessive grease. It can cause clutchslippage and judder.

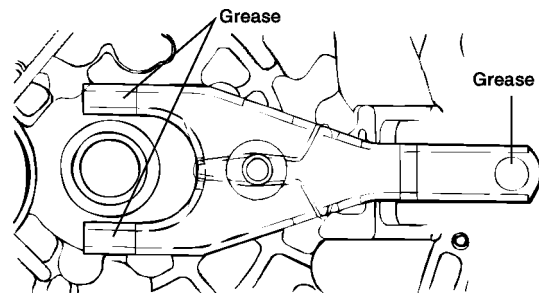

EODA019B

2. Apply multipurpose grease into the groove of the release bearing.

Grease: CASMOLY L9508

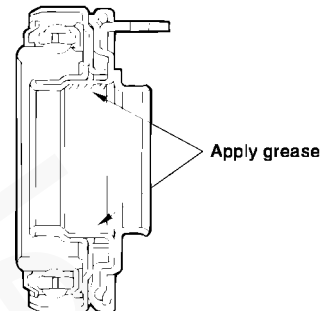

EODA019A

3. Apply multipurpose grease to the clutch release lever fulcrum contact surface of the clutch release fork assembly.

Grease: CASMOLY L9508

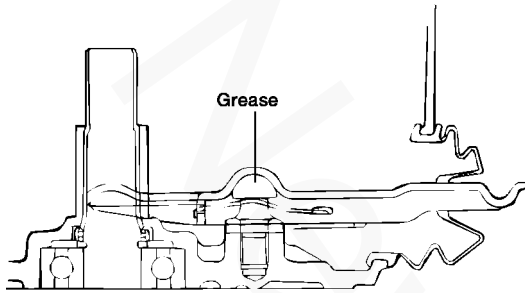

EODA019C

4. Clean the surfaces of the flywheel and pressure plate thoroughly with fine sandpaper or crocus cloth, and make certain that all oil or grease has been removed.
5. Apply a small amount of multipurpose grease to the clutch disc splines and input shaft splines.

Grease: CASMOLY L9508

CAUTION

Do not apply more grease than necessary. Too much grease could cause clutch slip or judder.

6. Using the special tool (09411-25000), install the clutch disc to the flywheel. When installing the clutch disc, be sure that the surface having the manufacturer's stamp is towards the pressure plate side.
7. Install the the clutch cover assembly onto the flywheel and install the six (6) bolts through the clutch cover into the flywheel.

8. Tighten the bolts by one or two turns at a time, in succession, to avoid bending the cover flange. If a special tool is not available, tighten the bolt temporarily and then torque to specification in diagonal torquing sequence indicated below.

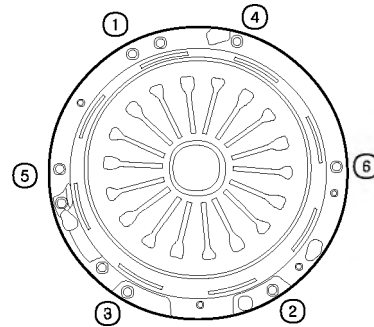

E00E100A

TIGHTENING TORQUE

Single mass flywheel:
 15~22 N·m (150~220 kgf·cm, 11~16 lbf·ft)
 Dual mass flywheel:
 20~27 N·m (200~270 kgf·cm, 14~19 lbf·ft)

9. Remove the special tool.
10. Install the transaxle. (Refer to GROUP - Manual Transaxle Assembly)
11. Adjust the clutch pedal free-play. (See CH-6)

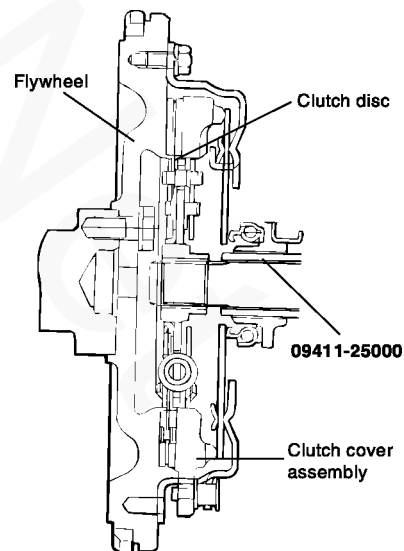

EODA120A

CLUTCH MASTER CYLINDER

COMPONENTS EAC2D9FE

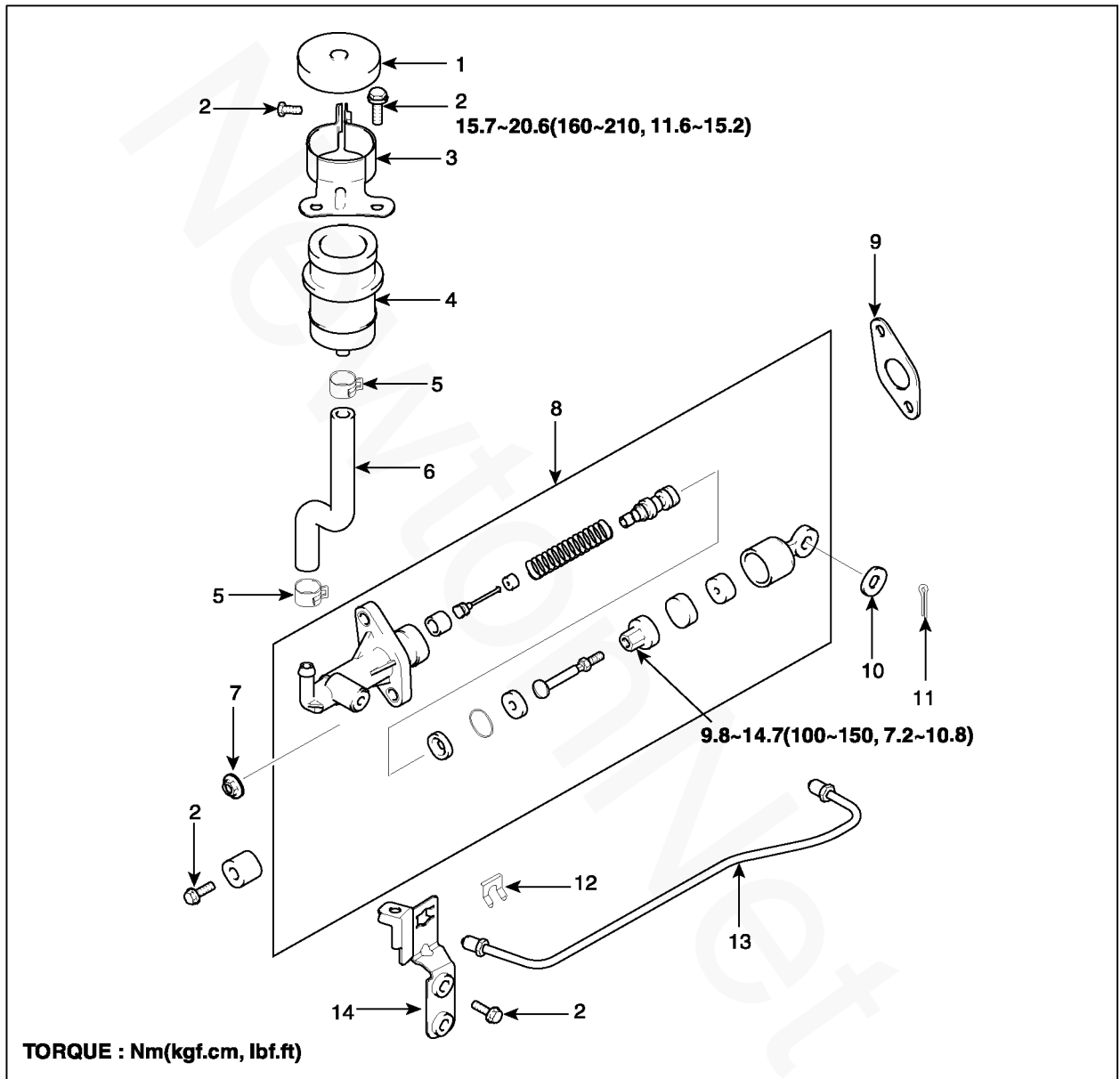

- 1. Reservoir cam assembly
- 2. Bolt
- 3. Reservoir mounting bracket
- 4. Clutch master cylinder reservoir
- 5. Clutch tube clip
- 6. Reservoir hose
- 7. Nut

- 8. Clutch master cylinder assembly
- 9. Sealer
- 10. Plain washer
- 11. Split pin
- 12. Hose clip
- 13. Clutch tube
- 14. Clutch tube bracket

DISASSEMBLY E4E69E0D

1. Remove the reservoir band, reservoir tank and reservoir cap.
2. Remove the piston stop ring.
3. Pull out the push rod and piston assembly.

**NOTE**

Be careful not to damage the master cylinder body and piston assembly.

INSPECTION E98DC4AA

1. Check the inside of the cylinder body for rust, pitting or scoring.
2. Check the piston cup for wear or distortion.
3. Check the piston for rust, pitting or scoring.
4. Check the clutch tube line for obstructions.
5. Measure the clutch master cylinder inside diameter with a cylinder gauge and the piston outside diameter with a micrometer.

**NOTE**

Measure the inside diameter of the clutch master cylinder in three places (bottom, middle, and top), in perpendicular directions.

6. If the clutch master cylinder-to-piston clearance exceeds the limit, replace the master cylinder and/or piston assembly.

Limit: 0.15 mm (0.006 in.)

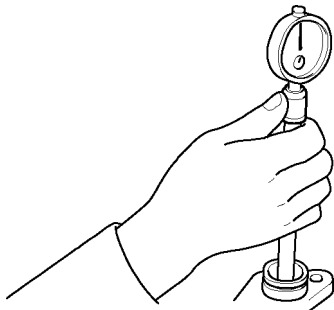

EODA014A

REASSEMBLY ED731BA1

1. Apply the specified fluid to the inner surface of the cylinder body and to the outside of the piston assembly.

Specified fluid: BRAKE FLUID DOT 3 or DOT 4

2. Install the piston assembly.
3. Install the piston stop ring.
4. Install the push rod assembly.

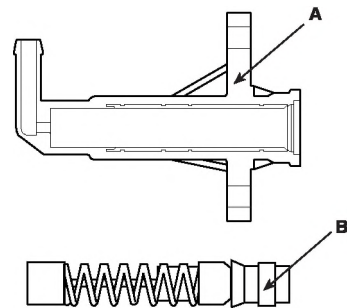

EODA014B

5. Install the reservoir band, reservoir tank and reservoir cap.

CLUTCH PEDAL

COMPONENTS EFBA3914

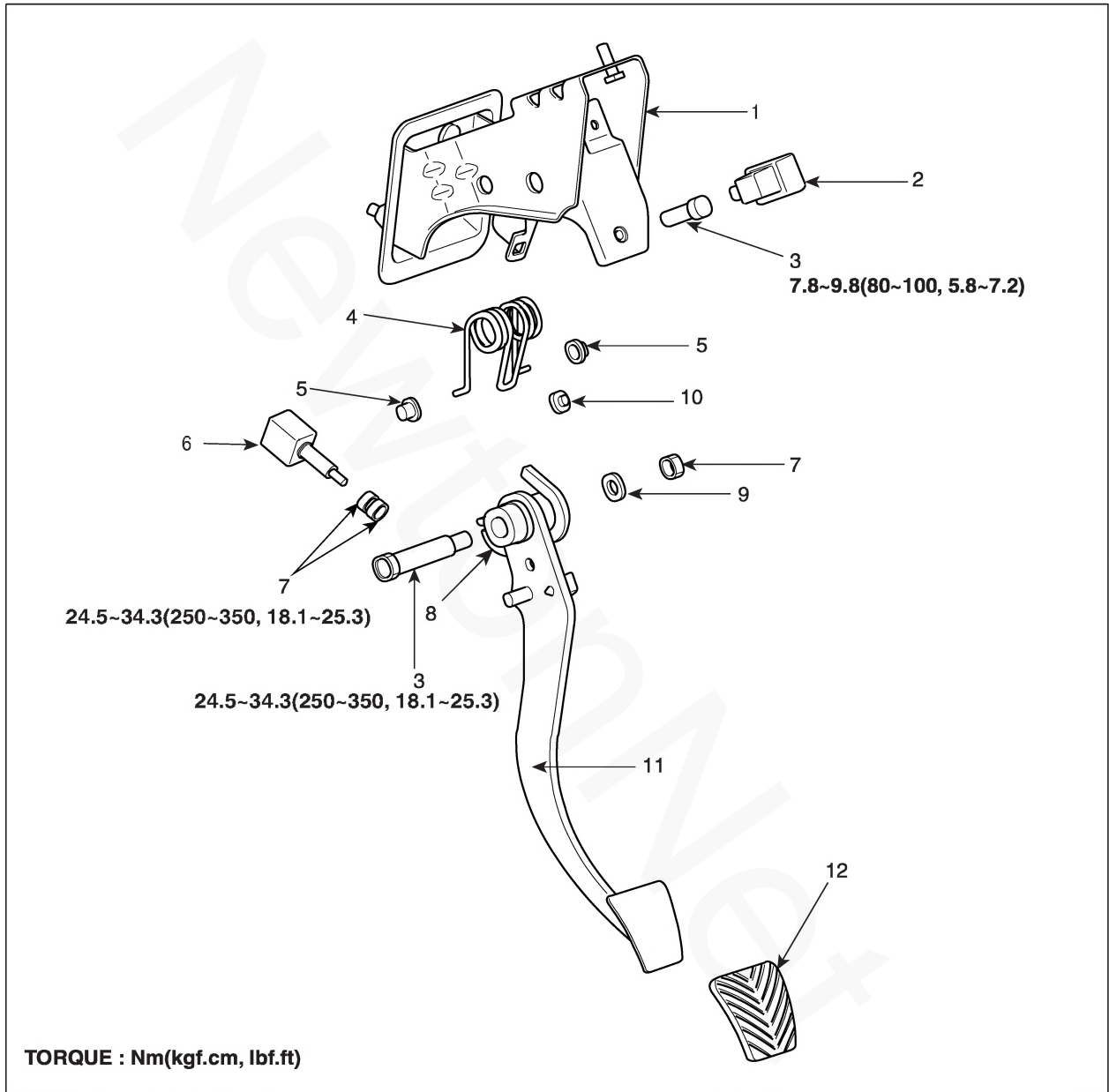

TORQUE : Nm(kgf.cm, lbf.ft)

- 1. Clutch pedal bracket
- 2. Stop lamp switch assembly
- 3. Bolt
- 4. Turn over spring
- 5. Bush
- 6. Clutch pedal position switch assembly

- 7. Nut
- 8. Clutch pedal bush
- 9. Spring washer
- 10. Rubber stopper
- 11. Clutch pedal
- 12. pedal pad

REMOVAL E2DC6E23

1. Remove the cotter pin, washer and clevis pin.
2. Remove the clutch pedal mounting bolt.

INSPECTION ECDB823F

1. Check the clutch pedal shaft and bushing for wear.
2. Check the clutch pedal for bending or distortion.
3. Check the return spring for damage or deterioration.
4. Check the clutch pedal pad for damage or wear.

IGNITION LOCK SWITCH INSPECTION

Check for continuity between terminals.

Terminal	1	2
Condition		
Pushed		
Free		

EODA009A

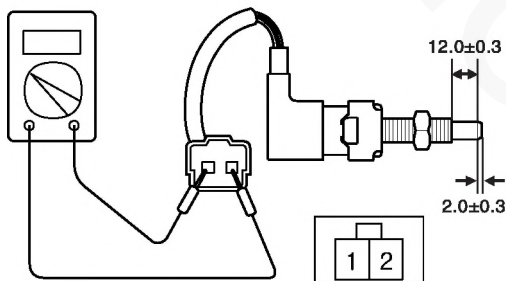

E00B059C

INSTALLATION E8641C37

1. Installation is the reverse of removal.
2. Apply multi-purpose grease to the bushings.

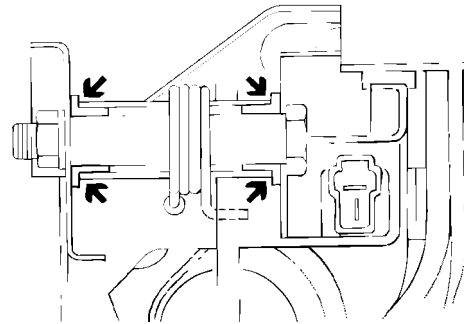

EODA009B

3. Apply multi-purpose grease to the clevis pin and washer.
4. Install the push rod to the clutch pedal.
5. Adjust the clutch pedal clevis pin play.

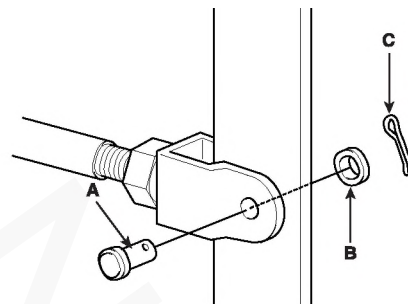

E00F510A

CLUTCH RELEASE CYLINDER

COMPONENTS E135E9C4

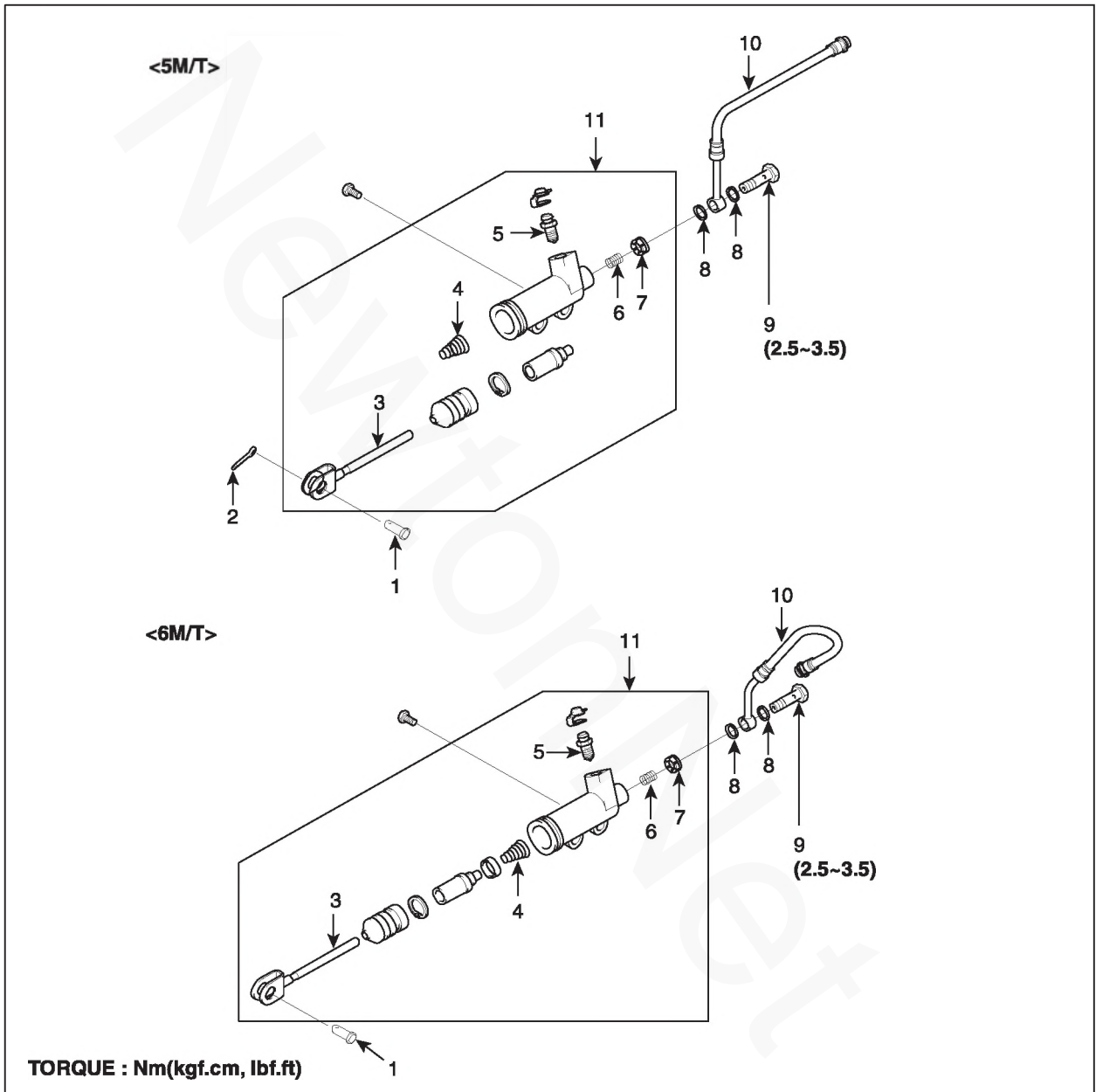

- | | |
|------------------|--|
| 1. Clevis pin | 7. Clutch release cylinder plate valve |
| 2. Split pin | 8. Clutch release cylinder gasket |
| 3. Push rod | 9. Union bolt |
| 4. Return spring | 10. Clutch hose assembly |
| 5. Bleeder screw | 11. Clutch release cylinder assenbly |
| 6. Valve spring | |

CLUTCH SYSTEM

CH -17

REMOVAL ED6907D3

1. Disconnect the clutch tube.
2. Remove the clutch release cylinder mounting bolt.

INSTALLATION EAE95458

1. Coat the clevis pin with the specified grease.

Specified grease: CASMOLY L9508

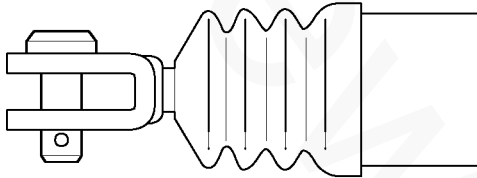

E00F512A

2. Install the clutch release cylinder, and the clutch tube.

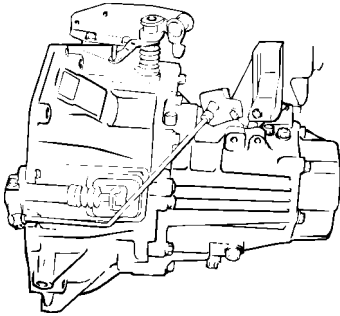

E0DA011A

DISASSEMBLY EFBC496B

1. Remove the clutch hose, valve plate, spring, push rod and boot.
2. Remove any dirt from the piston bore opening of the release cylinder.
3. Remove the piston from the release cylinder using compressed air.

CAUTION

1. **Cover the release cylinder with rags to prevent the piston from popping out and causing injury.**
2. **Apply compressed air slowly to prevent the fluid from splashing in your eyes or on your skin.**

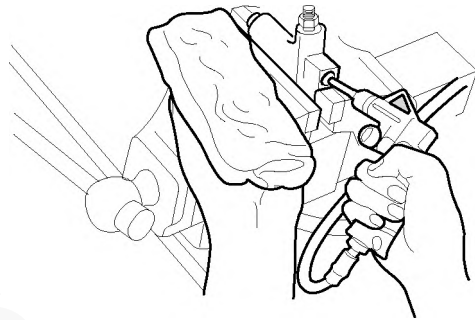

E0DA016A

INSPECTION E85E24ED

1. Check the clutch release cylinder for fluid leakage.
2. Check the clutch release cylinder boots for damage.
3. Check the release cylinder bore for rust and damage.
4. Measure the release cylinder bore at three locations (bottom, middle and top) with a cylinder gauge and replace the release cylinder assembly if the bore-to-piston clearance exceeds the limit.

Limit: 0.15 mm (0.006 in.)

REASSEMBLY E3CEEE7A

1. Apply specified brake fluid to the release cylinder bore and the outer surface of the piston and piston cup, and push the piston cup assembly into the cylinder.

Use the specified fluid:
Brake fluid DOT 3 or DOT 4

2. Install the valve plate, push rod and boot.

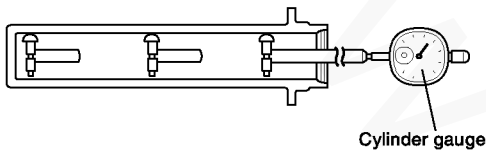

EODA016B