

# Installation instructions

## for contractors

**VIESSMANN**

## Cylinder demand terminal box

for the Vitodens 100-W, type WB1B

---

### Safety instructions



**Please follow these safety instructions closely to prevent accidents and material losses.**

Installation, initial start-up, inspection, maintenance and repairs must only be carried out by a competent person (heating engineer/installation contractor).

Before working on the equipment/heating system, isolate the power supply (e.g. by removing a separate mains fuse or by means of a mains isolator) and safeguard against unauthorised reconnection.

When using gas as fuel, also close the main gas shut-off valve and safeguard against unauthorised reopening.

Repairing components which fulfil a safety function can compromise the safe operation of your heating system.

For replacements, use only original spare parts supplied or approved by Viessmann.

### Function

The heat demand issued by the cylinder thermostat is transferred via the terminal box to the boiler control unit.

## Fitting the terminal box

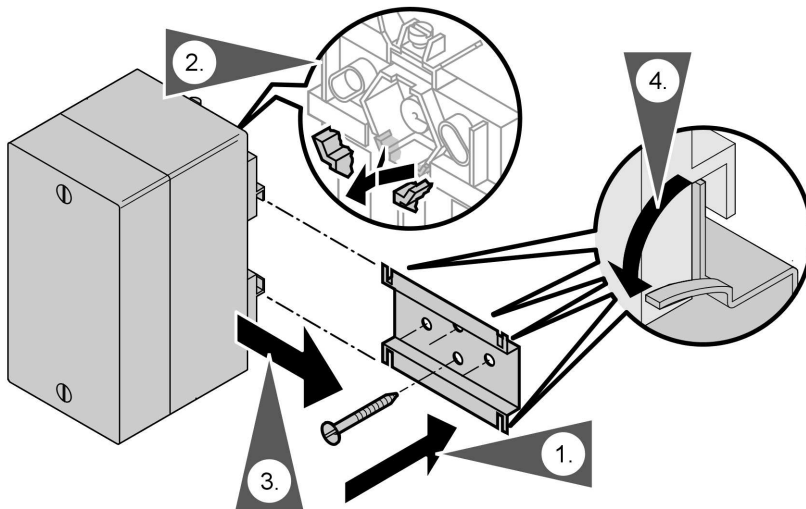

1. Secure the mounting bracket to the wall.
2. On the back of the casing, break off the knock-out webs with pliers.
3. Push the casing onto the wall mounting bracket.
4. Bend the tabs into the wall mounting bracket.

## Electrical connections

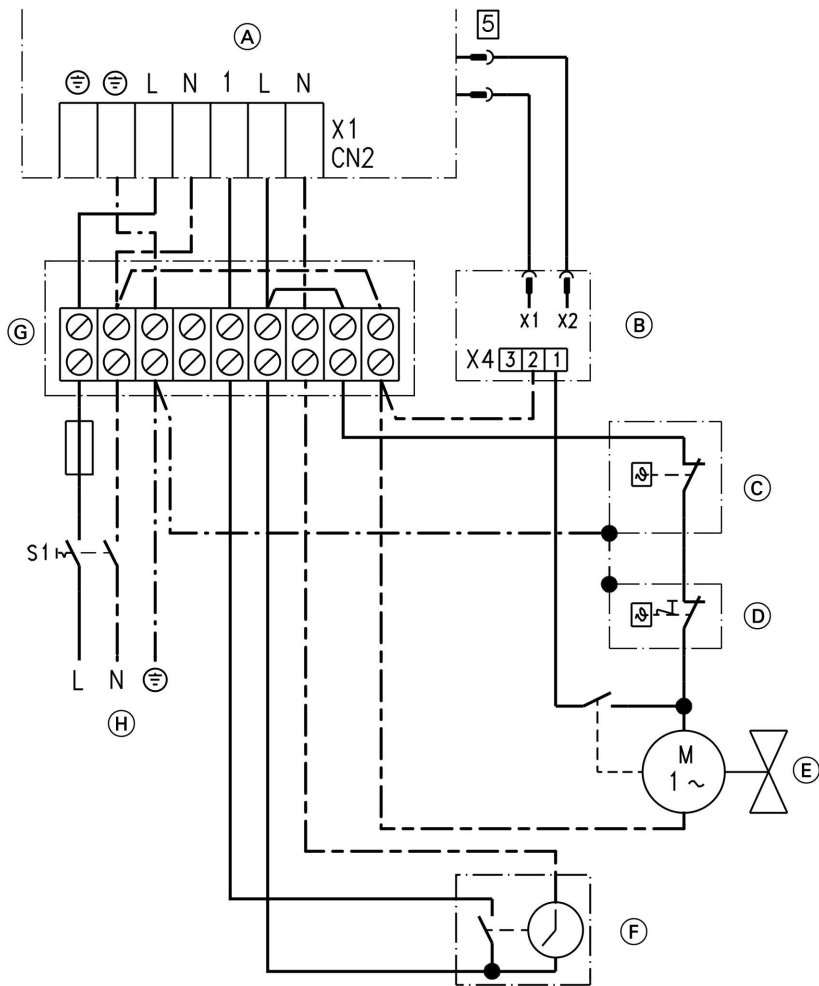

- (A) Terminals in the control unit
- (B) Cylinder demand terminal box
- (C) Cylinder thermostat
- (D) Safety temperature sensor
- (E) Valve
- (F) Room thermostat (clock thermostat)
- (G) Terminal box (on site)
- (H) Power supply 230 V, 50 Hz

5366 018 GB

1. Remove the lid from terminal box

(B).



## Electrical connections (cont.)

2. Make on-site wiring to X4.1 and X4.2 terminal box (B) according to the connection diagram.  
Apply the strain relief to the cable.
3. Replace the lid of terminal box (B).
4. Connect the cable from terminal box (B) to plugs [5] of the cable harness inside the boiler.



Boiler installation instructions

Viessmann Werke GmbH&Co KG  
D-35107 Allendorf  
Telephone: +49 6452 70-0  
Fax: +49 6452 70-2780  
[www.viessmann.com](http://www.viessmann.com)

Viessmann Limited  
Hortonwood 30, Telford  
Shropshire, TF1 7YP, GB  
Telephone: +44 1952 675000  
Fax: +44 1952 675040  
E-mail: [info-uk@viessmann.com](mailto:info-uk@viessmann.com)

Printed on environmentally friendly,  
chlorine-free bleached paper



5366 018 GB Subject to technical modifications.